

---

# Bjælker

Tolerancer og tværsnitsdata

---

UPE-bjælke

Tværsnitsdata

Profil nr	Tværsnitsmål						Arealer og masse		
	h	b	d	t	R <sub>1</sub>	R <sub>2</sub>	F	A	g
UPE 80	80	50	4,0	7,0	10	2,0	0,34	1010	7,90
UPE 100	100	55	4,5	7,5	10	2,5	0,40	1250	9,82
UPE 120	120	60	5,0	8,0	12	2,5	0,46	1540	12,1
UPE 140	140	65	5,0	9,0	12	2,5	0,52	1840	14,5
UPE 160	160	70	5,5	9,5	12	3,0	0,58	2170	17,0
UPE 180	180	75	5,5	10,5	12	3,0	0,64	2510	19,7
UPE 200	200	80	6,0	11,0	13	3,0	0,70	2900	22,8
UPE 220	220	85	6,5	12,0	13	3,5	0,76	3390	26,6
UPE 240	240	90	7,0	12,5	15	3,5	0,81	3850	30,2
UPE 270	270	95	7,5	13,5	15	4,0	0,89	4480	35,2
UPE 300	300	100	9,5	15,0	15	4,5	0,97	5660	44,4
UPE 330	330	105	11,0	16,0	18	4,5	1,04	6780	53,2
UPE 360	360	110	12,0	17,0	18	5,0	1,12	7790	61,2
UPE 400	400	115	13,5	18,0	18	5,0	1,22	9190	72,2
Enhed	mm	mm	mm	mm	mm	mm	m <sup>2</sup> /m	mm <sup>2</sup>	kg/m

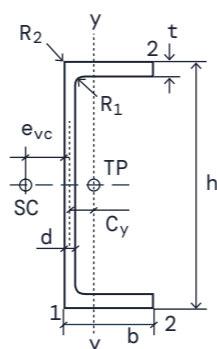

Almindelige ståltyper ved lagerlevering:

EN 10025-2:2004 S355J2 (UPE80-400)  
EN 10025-2:2004 S275JR (UPE80-400)

Tolerancer

I henhold til EN 10279

Længdetolerance

Standard + 100/-0 mm.

Vægttolerance

Pr. længde er den tilladte vægtafvigelse per meter ±6 % for h≤125 mm. Ved h>125 ±4 %. Ved bestemmelse af vægttolerance sammenlignes den teoretiske vægt med den vejede vægt.

Tværsnitstolerance							
h	b	d	t*				
80	±2,0	50	±1,5	4,0	±0,5	7,0	-0,5
100	±2,0	55	±2,0	4,5	±0,5	7,5	-0,5
120	±2,0	60	±2,0	5,0	±0,5	8,0	-0,5
140	±2,0	65	±2,0	5,0	±0,5	9,0	-0,5
160	±2,0	70	±2,0	5,5	±0,5	9,5	-0,5
180	±2,0	5,5	±2,0	5,5	±0,5	10,5	-1,0
200	±2,0	6,0	±2,0	6,0	±0,5	11,0	-1,0
220	±3,0	6,5	±2,0	6,5	±0,5	12,0	-1,0
240	±3,0	7,0	±2,0	7,0	±0,5	12,5	-1,0
270	±3,0	7,5	±2,0	7,5	±0,5	13,5	-1,0
300	±3,0	9,5	±2,0	9,5	±0,5	15,0	-1,0
330	±3,0	11,0	±2,5	11,0	±0,7	16,0	-1,5
360	±3,0	12,0	±2,5	12,0	±0,7	17,0	-1,5
400	±3,0	13,5	±2,5	13,5	±0,7	18,0	-1,5
mm	mm	mm	mm	mm	mm	mm	mm

\* Flangetykkelse. Plustolerancer bestemmes af vægttolerancen.

Formtolerance

Planhed f	
h≤100	±0,5
100<h≤200	±1,0
200<h≤400	±1,5

Retvinklethed	
b	k+k <sub>1</sub>
b≤100	2,0
100<b	2,5% af b

Rethed qyy	
h≤150	±0,5% af L
150<h≤300	±0,3% af L
300<h	±0,2% af L

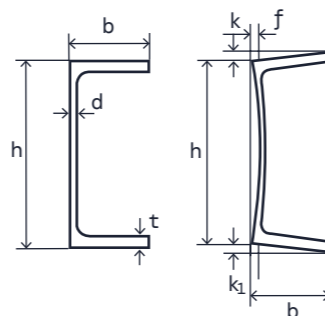
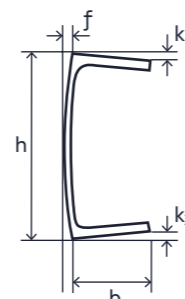
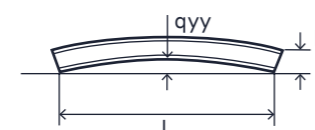

Rethed qxx	
h≤150	±0,3% af L
150<h≤300	±0,2% af L
300<h	±0,15% af L

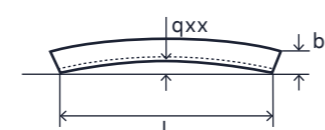

U-stang og UNP-bjælke

Tværsnitsdata

Profil nr	Tværsnitsmål						Arealer og masse		
	h	b	d	t	R <sub>k</sub>	R <sub>f</sub>	F	A	g
U 30	30	33	5,0	7,0	7,0	3,5	0,170	544	4,22
U 40×20	40	20	5,0	5,5	5,0	2,5	0,142	366	2,73
U 40	40	35	5,0	7,0	7,0	3,5	0,198	621	4,87
U 50×25	50	25	5,0	6,0	6,0	3,0	0,181	492	4,14
U 50	50	38	5,0	7,0	7,0	3,5	0,229	712	5,6
U 60	60	30	6,0	6,0	6,0	3,0	0,215	646	5,1
U 65	65	42	5,5	7,5	7,5	4,0	0,273	903	7,1
U 80	80	45	6,0	8,0	8,0	4,0	0,313	1102	8,64
U 100	100	50	6,0	8,5	8,5	4,5	0,372	1345	10,6
U 120	120	55	7,0	9,0	9,0	4,5	0,429	1699	13,4
U 140	140	60	7,0	10,0	10,0	5,0	0,487	2037	16,0
U 160	160	65	7,5	10,5	10,5	5,5	0,545	2401	18,8
U 180	180	70	8,0	11,0	11,0	5,5	0,603	2797	22,0
U 200	200	75	8,5	11,5	11,5	6,0	0,660	3218	25,3
U 220	220	80	9,0	12,5	12,5	6,5	0,718	3744	29,4
U 240	240	85	9,5	13,0	13,0	6,5	0,776	4231	33,2
U 260	260	90	10,0	14,0	14,0	7,0	0,833	4828	37,9
U 280	280	95	10,0	15,0	15,0	7,5	0,890	5330	41,8
U 300	300	100	10,0	16,0	16,0	8,5	0,949	5876	46,2
U 320	320	100	14,0	17,5	17,5	8,75	0,982	7580	59,5
U 350	350	100	14,0	16,0	16,0	8,0	1,050	7730	60,6
U 400	400	110	14,0	18,0	18,0	9,0	1,180	9150	71,8
Enhed	mm	mm	mm	mm	mm	mm	m <sup>2</sup> /m	mm <sup>2</sup>	kg/m

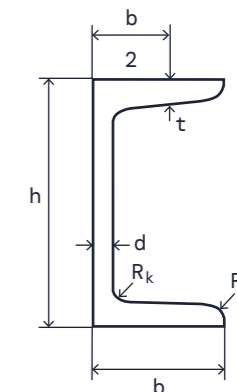

Almindelige ståltyper ved lagerlevering:

EN 10025-2:2004 S275JR (U30-220)  
EN 10025-2:2004 S355J2 (U80-400)

Tolerancer

I henhold til EN 10279

Længdetolerance

Standard + 100/-0 mm.

Vægttolerance

Pr. længde er den tilladte vægtafvigelse per meter ±6 % for h≤125 mm. Ved h>125 ±4 %. Ved bestemmelse af vægttolerance sammenlignes den teoretiske vægt med den vejede vægt.

Tværsnitstolerance

Højde h		Bredde b	
h≤65	±1,5	b≤50	±1,5
65<h≤200	±2,0	50<b≤100	±2,0
200<h≤400	±3,0	100<b≤125	±2,5
400<h	±4,0	125<b	±3,0

Flangetykkelse t*	
t≤10	-0,5
10<t≤15	-1,0
15<t	-1,5

Kropstykkelse d	
h≤100	±0,5
100<h≤200	±1,0
200<h≤400	±1,5
400<h	±1,5

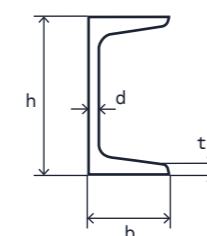

Formtolerance

Planhed f	
h≤100	±0,5
100<h≤200	±1,0
200<h≤400	±1,5

Retvinklethed	
b	k+k <sub>1</sub>
b≤100	2,0
100<b	2,5% af b

Rethed qyy	
h≤150	±0,5% af L
150<h≤300	±0,3% af L
300<h	±0,2% af L

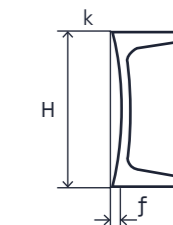
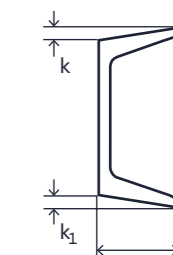
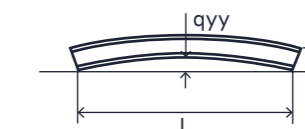

Rethed qxx	
h≤150	±0,3% af L
150<h≤300	±0,2% af L
300<h	±0,15% af L

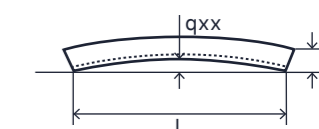

\* Plustolerancer bestemmes af vægttolerancen.

## IPE-bjælke

## Tværsnitsdata

Profil nr	Tværsnitsmål					Arealer og masse			
	h	b	t	d	R	F	A	A-liv	g
IPE 80	80	46	5,2	3,8	5	0,328	764	264	6,0
IPE 100	100	55	5,7	4,1	7	0,400	1032	363	8,1
IPE 120	120	64	6,3	4,4	7	0,475	1321	472	10,4
IPE 140	140	73	6,9	4,7	7	0,551	1643	593	12,9
IPE 160	160	82	7,4	5,0	9	0,623	2009	726	15,8
IPE 180	180	91	8,0	5,3	9	0,698	2395	869	18,8
IPE 200	200	100	8,5	5,6	12	0,768	2848	1025	22,4
IPE 220	220	110	9,2	5,9	12	0,848	3337	1189	26,2
IPE 240	240	120	9,8	6,2	15	0,922	3912	1366	30,7
IPE 270	270	135	10,2	6,6	15	1,04	4594	1647	36,1
IPE 300	300	150	10,7	7,1	15	1,16	5381	1978	42,2
IPE 330	330	160	11,5	7,5	18	1,25	6261	2303	49,1
IPE 360	360	170	12,7	8,0	18	1,35	7273	2677	57,1
IPE 400	400	180	13,5	8,6	21	1,47	8446	3208	66,3
IPE 450	450	190	14,6	9,4	21	1,61	9882	3956	77,6
IPE 500	500	200	16,0	10,2	21	1,74	11550	4774	90,7
IPE 550	550	210	17,2	11,1	24	1,88	13440	5723	106
IPE 600	600	220	19,0	12,0	24	2,01	15600	6744	122
Enhed	mm	mm	mm	mm	mm	m <sup>2</sup> /m	mm <sup>2</sup>	mm <sup>2</sup>	kg/m

## Almindelige ståltyper ved lagerlevering:

EN 10025-2:2004 S275JR (IPE 80-140) S355J2 (IPE 160-600)

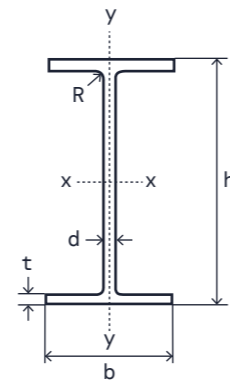

## HEA-bjælke

## Tværsnitsdata

Profil nr	Tværsnitsmål					Arealer og masse			
	h	b	t	d	R	F	A	A-liv	g
HEA 100	96	100	8,0	5,0	12	0,561	2124	400	16,7
HEA 120	114	120	8,0	5,0	12	0,677	2534	490	19,9
HEA 140	133	140	8,5	5,5	12	0,794	3142	638	24,7
HEA 160	152	160	9,0	6,0	15	0,906	3877	804	30,4
HEA 180	171	180	9,5	6,0	15	1,02	4525	912	35,5
HEA 200	190	200	10,0	6,5	18	1,14	5383	1105	42,3
HEA 220	210	220	11,0	7,0	18	1,26	6434	1316	50,5
HEA 240	230	240	12,0	7,5	21	1,37	7684	1545	60,3
HEA 260	250	260	12,5	7,5	24	1,48	8682	1688	68,2
HEA 280	270	280	13,0	8,0	24	1,60	9726	1952	76,4
HEA 300	290	300	14,0	8,5	27	1,72	11250	2227	88,3
HEA 320	310	300	15,5	9,0	27	1,76	12440	2511	97,6
HEA 340	330	300	16,5	9,5	27	1,79	13350	2822	105
HEA 360	350	300	17,5	10,0	27	1,83	14280	3150	112
HEA 400	390	300	19,0	11,0	27	1,91	15900	3872	125
HEA 450	440	300	21,0	11,5	27	2,01	17800	4577	140
HEA 500	490	300	23,0	12,0	27	2,11	19750	5328	155
HEA 550	540	300	24,0	12,5	27	2,21	21180	6150	166
HEA 600	590	300	25,0	13,0	27	2,31	22650	7020	178
Enhed	mm	mm	mm	mm	mm	m <sup>2</sup> /m	mm <sup>2</sup>	mm <sup>2</sup>	kg/m

## Almindelige ståltyper ved lagerlevering:

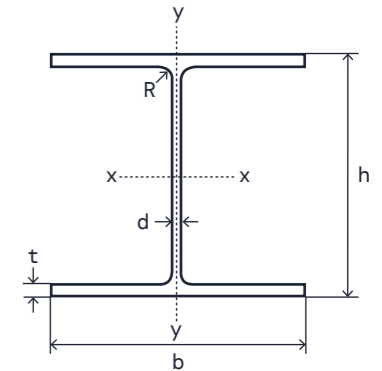
EN 10025-2:2004 S355J2 (HEA 100-600)  
EN 10025-2:2004 S275JR (HEA 100-180)

## HEB-bjælke

### Tværsnitsdata

Profil nr	Tværsnitsmål					Areal og masse			
	h	b	t	d	R	F	A	A <sub>liv</sub>	g
HEB 100	100	100	10,0	6,0	12	0,567	2604	480	20,4
HEB 120	120	120	11,0	6,5	12	0,686	3401	637	26,7
HEB 140	140	140	12,0	7,0	12	0,805	4296	812	33,7
HEB 160	160	160	13,0	8,0	15	0,918	5425	1072	42,6
HEB 180	180	180	14,0	8,5	15	1,04	6525	1292	51,2
HEB 200	200	200	15,0	9,0	18	1,15	7808	1530	61,3
HEB 220	220	220	16,0	9,5	18	1,27	9104	1786	71,5
HEB 240	240	240	17,0	10,0	21	1,38	10600	2060	83,2
HEB 260	260	260	17,5	10,0	24	1,50	11840	2250	93,0
HEB 280	280	280	18,0	10,5	24	1,62	13140	2562	103
HEB 300	300	300	19,0	11,0	27	1,73	14910	2882	117
HEB 320	320	300	20,5	11,5	27	1,77	16130	3209	127
HEB 340	340	300	21,5	12,0	27	1,81	17090	3564	134
HEB 360	360	300	22,5	12,5	27	1,85	18060	3938	142
HEB 400	400	300	24,0	13,5	27	1,93	19780	4752	155
HEB 450	450	300	26,0	14,0	27	2,03	21800	5572	171
HEB 500	500	300	28,0	14,5	27	2,12	23860	6438	187
HEB 550	550	300	29,0	15,0	27	2,22	25410	7380	199
HEB 600	600	300	30,0	15,5	27	2,32	27000	8370	212
Enhed	mm	mm	mm	mm	mm	m <sup>2</sup> /m	mm <sup>2</sup>	mm <sup>2</sup>	kg/m

### Almindelige ståltyper ved lagerlevering:

EN 10025-2:2004 S355J2 (HEB100-600)  
EN 10025-2:2004 S275JR (HEB100-300)

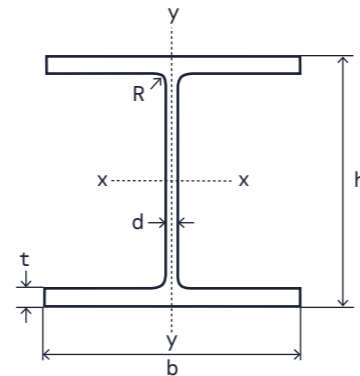

## Tolerancer

### IPE, HEA og HEB-bjælke

I henhold til EN 10 034

#### Længdetolerance

Standard + 100/-0 mm.

#### Vægttolerance

Pr. længde ± 4 %.

#### Tværsnitstolerancer

Højde	
Profilhøjde	Tolerance
h ≤ 180	+3,0 -2,0
180 < h ≤ 400	+4,0 -2,0
400 < h ≤ 700	+5,0 -3,0

Kropstykkelser (d)	
Kropstykkelser	Tolerance
D < 7	±0,7
7 ≤ D < 10	±1,0
10 ≤ D < 20	±1,5
20 ≤ D < 40	±2,0
40 ≤ D < 60	±2,5
D ≥ 60	±3,0

Bredde	
Flangebredde	Tolerance
b ≤ 110	+4,0 -1,0
110 < b ≤ 210	+4,0 -2,0
210 < b ≤ 325	±4,0
b > 325	+6,0 -5,0

Flangetykkelse (t)	
Kropstykkelser	Tolerance
t < 6,5	+1,5 -0,5
6,5 ≤ t < 10	+2,0 -1,0
10 ≤ t < 20	+2,5 -1,5
20 ≤ t < 30	+2,5 -2,0
30 ≤ t < 40	±2,5
40 ≤ t < 60	±3,0
t ≥ 60	±4,0

#### Formtolerancer

Retvinklethed (k+k')	
Flangebredde	Tolerance
b ≤ 110	1,5
b > 110	2% af b (max 6,5 mm)

Flangeforskydning (e)		
t	Flangebredde	Tolerance e
t < 40	b ≤ 110	2,5
	110 < b ≤ 325	3,5
	b > 325	5,0
t < 40	110 < b ≤ 325	5,0
	b > 325	8,0

Rethed (q <sub>xx</sub> , q <sub>yy</sub> )	
Profilhøjde	Tolerance
80 < h ≤ 180	0,003L
180 < h ≤ 360	0,0015L
h > 360	0,001L

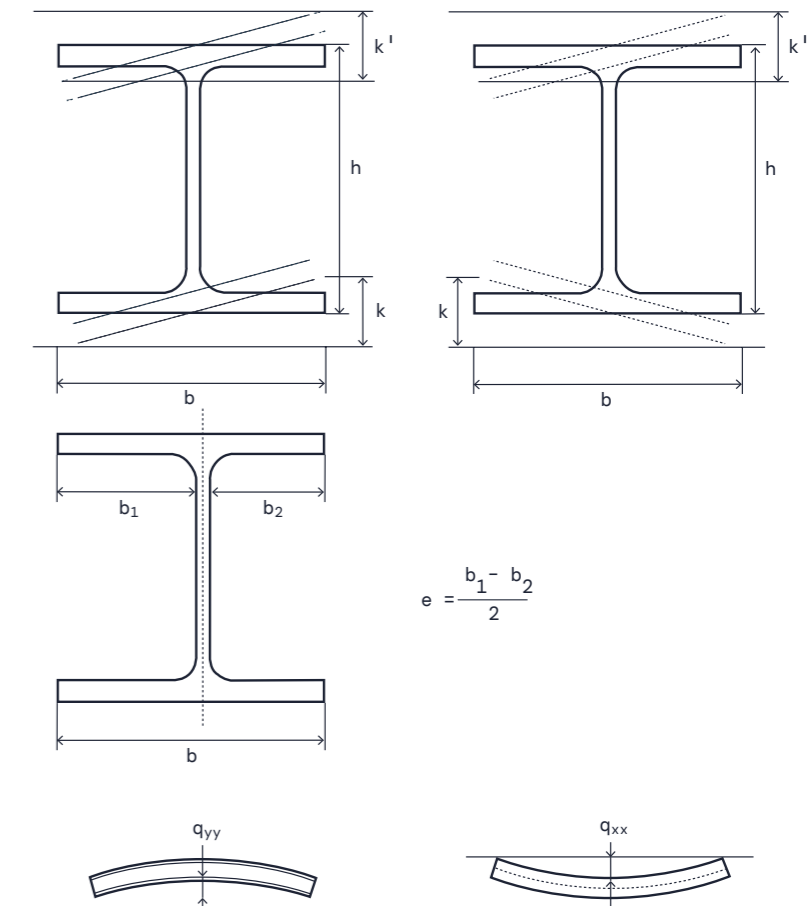

# TIBNOR

Tibnor er den førende stålleverandør i Norden og Baltikum. I tæt samarbejde med SSAB, vores leverandører og vores kunder forsyner Tibnor den nordiske og baltiske industri med det bredeste udvalg af produkter og tjenester inden for stål og metaller.